

DESCRIPTION

The **WS7.56-PCBA2** is a unique wavelength sensor based on silicon photodiode technology. The sensor is constructed monolithically by superimposing two photodiodes vertically. The active area is 7.56 mm² (2.7 mm X 2.7 mm). This device is most useful for wavelength de-termination of monochromatic light sources such as lasers and LED's. More component level information is available on the Wavelength Sensitive Photodiode on data sheet WS7.56-TO5.

The sensor is mounted on a PCB which contains all of the necessary circuitry to convert incident wavelength to an output voltage. The voltage is proportional to wavelength in the range of 450 nm to 850 nm. The output is independent of intensity. The circuit provides switched gain controls to accommodate various output requirements. As an example a typical output is 1.7 volts for a wavelength of 670 nm, with a gain setting of 5. The data in this sheet provides typical information. The actual output must be calibrated against known sources for accuracy. Resolution of 0.1 nm is possible. The circuit requires ±15 volts and consists of two logarithmic amplifiers and a ratio calculator. The sensor is mounted on a temperature sensor for reference. Applications include laser monitoring, matching of LED's and other light sources. A jumper is provided for optimizing photodiode biasing.

APPLICATIONS

- Precision photometry
- Analytical instruments
- Medical equipment
- Wavelength determination for monochromatic light



ABSOLUTE MAXIMUM RATING

SYMBOL	PARAMETER	MIN	MAX	UNITS
T _{STG}	Storage Temp	-40	+100	°C
T _{OP}	Operating Temp	-20	+55	°C
V _S	Power Supply Voltage Recommended ±15V	±12.0	±18.0	V
I _S	Supply Current	20	-	mA
V _R	Applied Bias Voltage*	0	±10	V

SPECTRAL RESPONSE @ 23°C

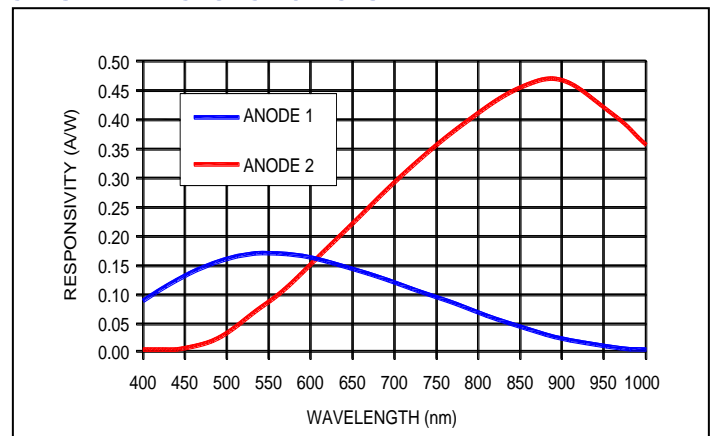

CONNECTION

PIN CONNECTIONS	
TP1	-15V
TP2	GND
TP3	+15V
TP4	WAVELENGTH OUT
TP5	TEMP OUT

ELECTRO-OPTICAL CHARACTERISTICS @ 23° C

SYMBOL	CHARACTERISTIC	TEST CONDITIONS	MIN	TYP	MAX	UNITS
V _O	Output Voltage		-4.5	---	+6.0	V
I _O	Output Current Limit (Temp sensor)		---	---	10	mA
	Input Dynamic Range	V _S = ± 15 V; V _R = 0 V	0.01	---	3	mW
	Spectral responsivity	Diode 1; λ = 550 nm	---	0.17	---	A/W
	Spectral responsivity	Diode 2; λ = 890 nm	---	0.45	---	A/W

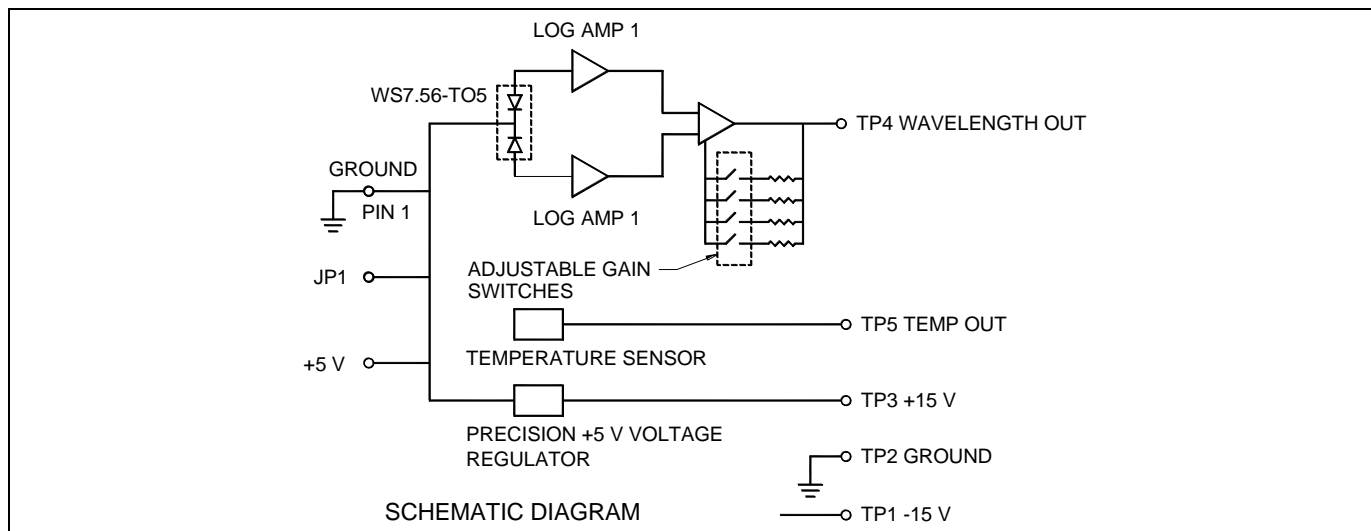

APPLICATION NOTES

Description

The WS7.56-PCBA2 is a circuit board complete with a precision wavelength sensing diode array, a precision temperature sensor and processing circuitry. Two output signals are 1) a voltage output proportional to the wavelength of the light sensed by the photodiode array and 2) a voltage output proportional to the temperature of the case of the photodiode array. The photodiode array is made using silicon technology. The WS7.56-PCBA2 is rated for the wavelength range of 450 nm to 850 nm. It is best suited to determine the wavelength of monochromatic light.

Operation

The magnitude of the wavelength voltage output is controlled by three slide switches that change the gain amplifier. The gain ranges are shown in table 1.

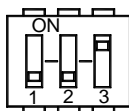

GAIN	SWITCH POSITIONS	
	ON	OFF
5.0	3	1 & 2
3.0	2	1 & 3
1.9	3 & 2	1
1.0	1	3 & 2

Table 1. GAIN ADJUSTMENT

Figure 1 shows the typical output voltage versus wavelength for a gain of 5. The voltage out will be relative to the spectral density center. That is, the actual output voltage will be related to the integral of the combination of the spectral response curve and the spectral content of the light input. Assuming the light input is very near a single wavelength (i.e., assuming a good laser source) the voltage out will be a good analog of the wavelength of the light source. Under optimum conditions of light intensity and wavelength spectral resolutions down to 1.0 nm are possible.

Detector Characteristics

The detector used is the WS7.56-TO5. Please see the WS7.56-TO5 data sheet for specifications for this detector response.

Temperature Considerations

The WS7.56-PCBA2 operating temperature range is -20 °C to +55 °C. The wavelength output has a temperature dependence of 1 nm per degree C. Variations in temperature will cause changes to dark currents that can affect accuracy. The circuitry also includes a precision temperature sensor LM35 from National Semiconductor. This sensor allows users to calibrate the wavelength output based on the temperature of the wavelength detector. The temperature sensor output is 10 mV per degree C, and is typically accurate to ±0.25 °C. The range of the temperature sensor is from +2 °C to +150 °C. If additional information is needed for the temperature sensor component specifications or circuit suggestions please see the LM35 data sheet on the National Semiconductor website.

Detector Bias

The circuitry provides a jumper JP1, to allow either a zero volt bias or an internal 5 volt bias to the photodiode array. The zero volt bias eliminates dark currents from the photodiode array, enabling better results over varying temperatures. The 5 volt bias slightly extends the NIR performance range and increases frequency response. For bias options other than 0 V and 5 V, remove the jumper and connect an external bias supply directly to the center pin JP1.

Frequency Response

The amplifier used is a logarithmic amplifier and consequently the frequency response is a function of the input signal amplitude. For typical input signals in the 0.5 milliwatt range and wavelengths in the range of 450 nm to 850 nm the -3db frequency response will be approximately 10 KHz with the 5 V bias option engaged.

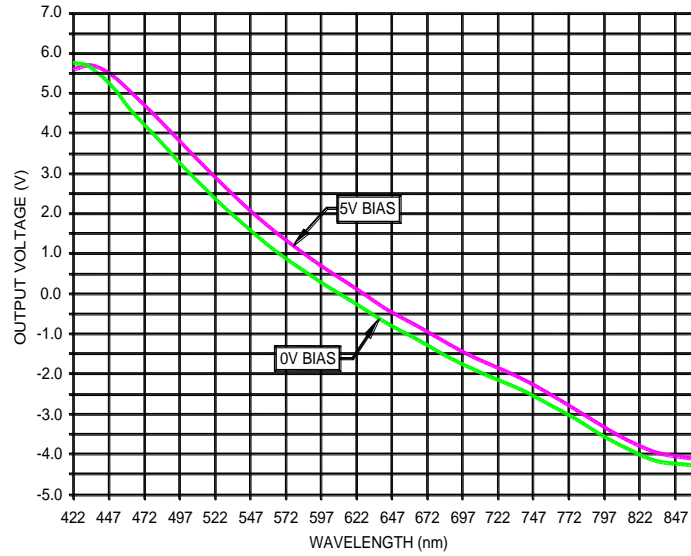

FIG. 1 VOLTAGE OUT VS WAVELENGTH @ 23°C*

*Typical values. Calibrate using known light sources.



USA

First Sensor Inc.
 5700 Corsa Avenue, #105
 Westlake Village, CA 91362 USA
 T + 818 706-3400
 F + 818 889-7053
 contact.us@first-sensor.com
 www.first-sensor.com

International sales

First Sensor AG
 Peter-Behrens-Str. 15
 12459 Berlin, Germany
 T + 49 30 6399 2399
 F + 49 30 639923-752
 sales.opto@first-sensor.com
 www.first-sensor.com